



USER'S MANUAL

Version 2024-04



PHAENON XD Full Color Laser Projector



LaserAnimation Sollinger GmbH | Crellestr. 19/20 | D-10827 Berlin
Phone +49 (30) 780 963 00 | Fax +49 (30) 780 963 25
Email info@laseranimation.com | www.laseranimation.com
Copyright © LaserAnimation Sollinger GmbH. All rights reserved



Legal Notice

LaserAnimation Sollinger GmbH reserves the right to make changes to its products for the purpose of technical improvement. These changes are not necessarily documented in each specific case. This document and the information contained herein have been prepared with the utmost care. No responsibility can be taken for the unlikely case of printing or other errors and any resulting damage.

This device is a show laser device for commercial use. This device is not a laser pointer and it must not be used for pointing purposes.

The brands and product names mentioned in this manual are trademarks or registered trademarks of their respective owners. Information in this document is subject to change without notice and does not represent a commitment on the part of the manufacturer LaserAnimation Sollinger GmbH.

No part of this manual may be reproduced or transmitted in any form or by any means, electronic or mechanical, including photocopying, recording, or information storage and retrieval systems, for any purpose other than for the purchaser's personal use, without written permission.



LaserAnimation Sollinger GmbH | Crellestr. 19/20 | D-10827 Berlin
Phone +49 (30) 780 963 00 | Fax +49 (30) 780 963 25
Email info@laseranimation.com | www.laseranimation.com
Copyright © LaserAnimation Sollinger GmbH. All rights reserved



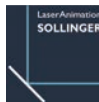

Contents

1 Contents of Package 5

2 Safety Hints 6

2.1 General Hints 6

2.2 Hints for Laser Safety 8

3 Product Information 10

4 Connectors. 12

4.1 Overview. 12

4.2 Connectors 13

4.2.1 Mains Connection. 13

4.2.2 LAN 13

4.2.3 Connection an external signal source via ILDA 14

4.2.4 Internal ILDA and DMX signal sources: built-in Lasergraph DSP . . . 14

4.2.5 Remote Connection 15

4.2.6 DMX. 17

5 Installation and Commissioning 19

5.1 Installation 19

5.1.1 Attachment of the Yoke. 19

5.1.2 Mounting of the Yoke 20

5.1.3 Standing Operation. 21

5.1.4 Hanging Operation 21

5.1.5 Hints for Application of the included Beam Blocker 22

5.2 Commissioning 23

5.2.1 Power On 23

5.2.2 Laser On. 23

5.2.3 Blink sequences of the Status LED 25

6 Control. 26

6.1 Operation via LA.toolbox Software. 26





7 Pin Assignments 27

7.2 Remote Connector 28

7.2.1 Interlock Plug (included) 28

7.3 DMX 29

8 Grating Module 30

8.2 Default Assembly 31

8.3 Channel Assignment. 33

8.4 Controlling the Grating Module 38

8.4.1 DMX signal routing. 38

9 Maintenance Hints. 41

10 Malfunction 41

11 Operation with UPS 42

12 Technical Drawings - PHAENON XD (Regular Housing). 43

13 Technical Specifications 45

EU Declaration of Conformity. 48

Final statement. 49



I Contents of Package

Please make sure that all components were delivered correctly. Please also compare the separately supplied packing list. If something is missing, please contact your sales contact.

Name	No.	Picture
Laser projector	1	
powerCON TRUE1 / power cable	1	
Interlock plug XLR 7pin	1	
Set of keys	1	
Yoke fixing screws M6x20	2	
Beam blocking set:	1	
• Blocking shade 110 mm	1	
• Blocking shade L-shaped 110 mm	2	
• Spacers	2	
Allen key 1.5, 2.0, 2.5 mm	3	
USB stick incl. manual	1	

The unit has been carefully packed for shipment. If you discover any damage to the unit or packing material due to improper shipping, please notify the shipping company and return the unit to the supplier, preferably in its original packaging.

2 Safety Hints

2.1 General Hints

1. The laser projector is intended only for proper use for projecting laser beams onto a projection surface (walls, screens) or into space indoors or outdoors.
2. The device may not be used when there is visible damage to the housing, the connectors in the rear, especially the electric power supply, or the connecting cables.
3. The installation should be performed by specially trained personnel. The projector should not be connected to the mains during installation. Please note the local safety regulations!
4. For operation of the laser unit at truss or on ceiling, the projector must be additionally secured by a safety cable. This cable must be appropriately designed according to the weight of the laser projector. The relevant accident prevention regulations of the professional associations must be observed.
5. If the provided mains cable does not correspond with your existing mains supply please use an appropriate adapter for mains connection. Do not use any electronically controlled sockets, e.g. no dimmer or radio sockets, for mains connection of the laser projector.
6. The laser unit has to be used according to this manual. LaserAnimation Sollinger GmbH does not assume liability for damages caused by non-observation of this manual.
7. Before starting any maintenance or cleaning remove the unit from the power supply!
8. In case of malfunctions please contact your dealer and after consultation send the device back for inspection and repair in its original packing. Do not open the device!

Attention: Warranty is rendered void if the device is misused, damaged, modified in any way, or for unauthorized repairs or parts.

9. The laser device is intended for use in a dry and sufficiently ventilated location. When used outdoors the device has to be protected against humidity, overheating and excessively low temperatures. Note the respective maximum and minimum ambient temperatures for operation specified in the technical details.



10. When operating the device in humid or special outdoor conditions that can lead to condensation:
- a. Allow the device to acclimatize sufficiently at the place of use.
 - b. Use LA.toolbox to check the internal temperature of the unit and the dew point.
 - c. Do not operate the device if the dew point is $> 20^{\circ}\text{C}$, as condensation can occur on the cooler components.
 - d. Do not switch the device off between operating times, simply activate interlock / E-stop to disable laser emission or set the laser projector state to Standby (refer to LA.toolbox main tabs). This prevents the unit from cooling down, as all temperature control loops remain active.
11. The laser unit may not be operated in environments polluted with sand, dust or acrid fumes or gases. Fog machines must not be operated in the immediate vicinity of the laser projector. Do not point the fog nozzle directly at the laser projector.
12. Do not expose the laser unit to direct sunlight or other intensive light sources e.g. spotlight.

2.2 Hints for Laser Safety

Caution – use of controls, adjustments or performance of procedures other than those specified herein may result in hazardous radiation exposure.

This laser product is designated as Class 4 during all procedures of operation, maintenance and service.

The local safety regulations for the application of Class 4 laser products must be observed!

1. Eye Protection

- **Never look directly into the laser beam!**
 A laser beam is coherent, monochromatic light with very high energy. A laser beam retains its intensity even over very long distances. If a laser beam hits the human eye it can lead to irreparable damages to the cornea, the conjunctiva, the eye lens and the retina. Avoid any reflections back into the laser to prevent damages to the laser system. Do not place any objects into the laser beam because even diffusely reflected radiation can cause eye damages. Therefore remove any rings, watches or the like before you carry out work on the device and use only non-reflective tools.
- We strictly recommend wearing laser protective glasses for laser devices according to laser class 4.

2. Fire Protection

- The high energy density of the laser beam causes painful burns when it hits human skin. The beam may also burn holes into textiles.
 Therefore never reach into the laser beam and do not let other parts of the body get in the way of the laser beam.
- If the laser beam hits easily flammable materials such as paper, these will ignite and a fire can develop very quickly. Therefore make sure that no flammable material is in the way of the beam before activating the laser.

3. Audience Protection

- The operation of laser systems with Class 4 lasers requires an emergency stop (E-Stop). Regardless of the way the laser is operated, an E-Stop must always be connected!
 Place the E-Stop so that you can reach it immediately in emergency situations. Run a test each time the laser is activated to ensure that it is turned off immediately by activating the E-Stop.
- Mark an area of about 3 to 4 m around the laser system as off limits to the audience.
- Only test the laser system as long as no audience is present.
- Never let the laser run unattended.
- Make sure that no unauthorized persons have access to your laser system.

The operation of laser equipment in the event sector with an audience requires an approval by a technical inspection authority in many countries!



2.3 Warning Labels

The operation of laser equipment in the event sector with an audience requires an approval by a technical inspection authority in many countries!

The following warning labels are placed on the laser device:

Next to emission laser window:



On the top cover:

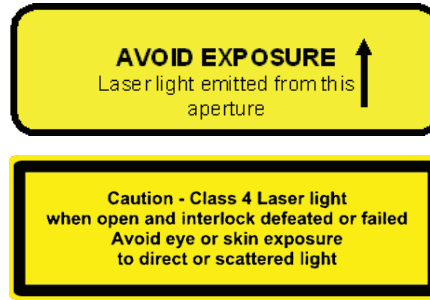

On the bottom:

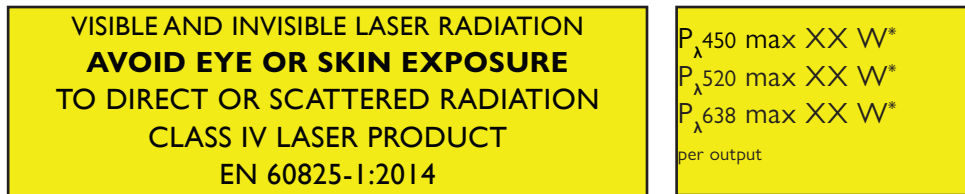

*depending on model

3 Product Information

The PHAENON XD projectors are equipped with high value color laser sources and fast X,Y CT scanners, allowing crisp projections in brilliant colors.

Special optical components for beam forming, beam combination and focusing and their professional placement and setup guarantee a sharp precise beam with a homogeneous beam profile and low divergence, even over longer distances.

Outstanding Features

- Electronic Masking sets new standards in the field of laser safety because it allows to define certain areas which can be perfectly protected against laser radiation
- Motorized Beam Adjustment allows an easy and comfortable adjustment of the beam superposition
- Outstanding Design with stable stainless steel yoke as well as output window protector
- Comfortable Control using “LA.toolbox” software installed on PC or Mac via LAN (Ethernet)

Laser Sources

Every PHAENON XD unit is based on a modular laser system.

PHAENON XD

One red and one blue module containing arrays with laser diode modules manufactured by LaserAnimation will be combined with a green OPSL Taipan laser module. Depending on the model a yellow or orange and a cyan Taipan laser module additionally can be integrated.

The integrated laser sources stand out due to their high beam quality in rich colors, low divergence as well as their enormous durability. The parameters for operating temperature and current set by the manufacturer of the laser sources are observed strictly in order to maximize their life expectancy.

Power Supply

The internal powerful power supply is completely isolated from other electronic components in order to ensure reliable operation even in unclean power grids.



LaserAnimation Sollinger GmbH | Crellestr. 19/20 | D-10827 Berlin
 Phone +49 (30) 780 963 00 | Fax +49 (30) 780 963 25
 Email info@laseranimation.com | www.laseranimation.com
 Copyright © LaserAnimation Sollinger GmbH. All rights reserved



Scanner Unit

The high value optical X,Y scanners CT-6210 (Cambridge Technology) in addition to the time-tested turbo scan driver electronics guarantee

- phenomenal precision with highest speed,
- outstanding projection quality,
- excellent thermal stability and
- perfect safety through the integrated scanner safety circuit, which immediately interrupts the laser emission in case of a malfunction.

Optics

The high value optics for beam combination and focusing are professionally arranged and perfectly adjusted during production. All laser colors are combined into a beam with high power density.

Optional Built-in Components

- **Grating Module**

This high value component makes the laser projector considerably more versatile. In addition to classic beams and graphics, a projector with integrated grating module can generate attractive laser patterns, allowing breathtaking effects not only on the projection screen but mainly in open space.

- **Laser Show Controller compact (PCB)**

With an integrated laser show controller the laser projector becomes a complete independent laser show system which can be used to play back as well as program laser shows.



ISO 9001:2015
certified

LaserAnimation Sollinger GmbH | Crellestr. 19/20 | D-10827 Berlin
Phone +49 (30) 780 963 00 | Fax +49 (30) 780 963 25
Email info@laseranimation.com | www.laseranimation.com
Copyright © LaserAnimation Sollinger GmbH. All rights reserved



4 Connectors

4.1 Overview



All included signal cables are shielded. In case you use other cables (e.g. for remote control, Interlock, external key switch) it is essential to use shielded cables only.

PHAENON XD front panel



PHAENON XD front panel

1. Laser aperture
2. Beam blocker mechanism
3. Emission LED

PHAENON XD back panel



PHAENON XD back panel

1. Key switch for controlling the laser emission
2. Laser emission indicator LED
3. Status LED
4. ILDA in: 25pin D-sub male to connect an ILDA compliant signal source
 ILDA thru: 25pin D-sub female for daisy chaining to other projectors
5. LAN to connect the device to Ethernet network for controlling by LA.toolbox
 LAN 1: Mainboard and LA.toolbox access
 LAN 2 and 3: Internal laser controller (subject to integration into projector)
6. DMX in: 5pin XLR male
 DMX thru: 5pin XLR female
 (Projectors with integrated Lasergraph DSP compact PCB are additionally equipped with DMX out)
7. Remote: 7pin XLR for connection of
 - emergency stop (E stop) (separately available)
 - included Interlock plug (to close the interlock loop for testing purposes)
8. Power connector powerCON TRUE1
 Universal input: 85 VAC – 264 VAC, 50 – 60 Hz

4.2 Connectors

4.2.1 Mains Connection

The projector can be operated with supply voltages of 185 VAC – 264 VAC / 50 – 60 Hz.
If the provided mains cable does not correspond with your existing mains supply please use an appropriate adapter for mains connection.



The projector must be operated with supply voltage with grounded protective conductor (PE)!

The highly-efficient power supply allows discharging external and internal disturbances via the protective conductor (PE). Internal filters are ineffective without protective conductor (PE).
Operation without grounded protective conductor (PE) can cause damage to the components of the power supply. For this we cannot provide any warranty!

4.2.2 LAN

The PHAENON XD can be integrated into an Ethernet network using the LAN interface and can be controlled using the LA.toolbox software installed on a PC or Mac.

For the Ethernet connection, either direct or using a switch, use standard CAT 5 patch cables with RJ-45 connectors.



CAT 5 PATCH NETWORK CABLE





A PC or a Mac is connected to the LAN interface for remote controlling of the internal Lasergraph DSP compact via Ethernet using the terminal software „LGRemote“.
 Details on the setup of the LAN port (IP address, DHCP etc.) can be found in the LA.toolbox Manual under the chapter “Network”.

4.2.3 Connection an external signal source via ILDA

All significant ILDA signals are true differential inputs i.e. each signal line must have its „inverted signal“ counterpart!
 At the signal source „inverted signal“ lines may be tied together and connected to GND.

Connect your projector to the 25pin ILDA output of a laser show controller, e.g. Lasergraph DSP compact or another controller with an ILDA compliant output.

4.2.4 Internal ILDA and DMX signal sources: built-in Lasergraph DSP compact, AVB module, FB4

The selection of the source for ILDA and DMX can be done independently of each other.

For Dante equipped projectors: The laser projector is controlled via the LAN 1 (Control) connection using the LA.toolbox software. The Dante board is accessed via the LAN 2 (Primary) and LAN 3 (Secondary) connections.

If the laser projector and the Dante board are to be accessed via the same cable, use the LAN 2 (Primary) connection and bridge the LAN 1 (Control) and LAN 3 (Secondary) connections with an appropriate cable.



4.2.5 Remote Connection

Different connections are possible:

I. Emergency Stop Switch (Interlock loop) with or without key switch

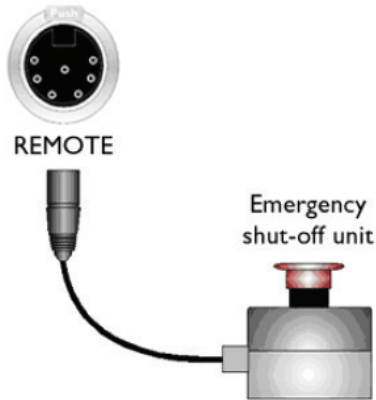

- The operation of laser systems with lasers class 4 requires an emergency stop (E-Stop). Regardless of the way the laser is operated, an E-Stop must always be connected.
- Place the E-Stop so that you can reach it immediately in emergency situations.
- Run a test each time the laser is activated to ensure that it is turned off immediately by activating the E-Stop.
- After activating the E-Stop (opening the interlock loop) your device is blocked from any laser emission.
To return to normal mode you have to deactivate (close the Interlock loop) and then to turn the Key switch to OFF an ON again.

Note:

On the remote connector the interlock loop is connected to pins 1 and 2.

2. Interlock Plug

If no E-Stop shall be used it is necessary that the included Interlock plug is inserted for closing the Interlock loop:



Remote



7pin plug
Interlock

An open Interlock loop means no laser output!

4.2.6 DMX

The DMX in- and outputs are only active if either a grating module and/or a Lasergraph DSP compact (PCB) or FB4 are/is installed.

PHAENON XD with Grating Module

The grating module can be controlled either manually or via DMX. The settings for the grating module can be adjusted using „LA.toolbox“ software.

You can connect any professional DMX lighting console to „DMX in“ for controlling the grating module. Please use 5pin standard cables marked EIA RS-485, shielded, twisted pair with 120 ohm surge impedance and low capacity (not included).

Please **do not use** microphone cables or cables with other characteristics than specified.



CABLE TYPE EIA RS-485 SHIELDED, TWISTED PAIR



The applied DMX signal at „DMX in“ is still available for transmission to other DMX devices at „DMX thru“.

Hint:

Please note that „DMX in“ is not terminated with 120 Ohm. This needs to be done externally (most easily using a terminating connector on „DMX thru“).

PHAENON XD with integrated Lasergraph DSP compact

The DMX output of the internal Lasergraph DSP compact is available as „DMX out“ on the outside of the projector in addition to „DMX in“ and „DMX thru“. This can be used to connect fog machines, dimmers or other DMX effect devices which can then be controlled using the internal Lasergraph DSP compact.

The „DMX in“ port of the laser projector is directly connected to the „DMX in“ input of the internal Lasergraph DSP compact.



PHAENON XD with Lasergraph DSP compact PCB and Grating Module

The Grating Module can be controlled either via a light console connected to the „DMX in“ or via the built-in Lasergraph DSP compact, AVB (integrated AVB2ILDA module) or via Dante (integrated DANTE2ILDA module).

The selection is made in the Main Tab of the software LA.toolbox under DMX Source or at the Terminal of the laser projector.

5 Installation and Commissioning

5.1 Installation

5.1.1 Attachment of the Yoke

The projector is usually supplied with mounted yoke. Both yoke locking plates are attached with the hexagon socket screws (M6x16) to the unit.

Only the yoke fixing screws have to be screwed on to circular plates.

Move the yoke to the desired position; possibly you have to loosen both M6 screws:



Screw on both yoke fixing screws to the circular yoke locking plates (lower hole) for fixing the yoke.



5.1.2 Mounting of the Yoke

If the yoke was removed and should be installed again, please observe the following hints:

1. Mount the yoke to the yoke holding plates attached on both sides of the projector.
2. Mount the circular yoke locking plates as follows: The plates are equipped with a smaller (1) and a slightly larger hole (2). The smaller one is provided for the Allen screw (above), the larger one for the yoke fixing screw (below), compare pictures:

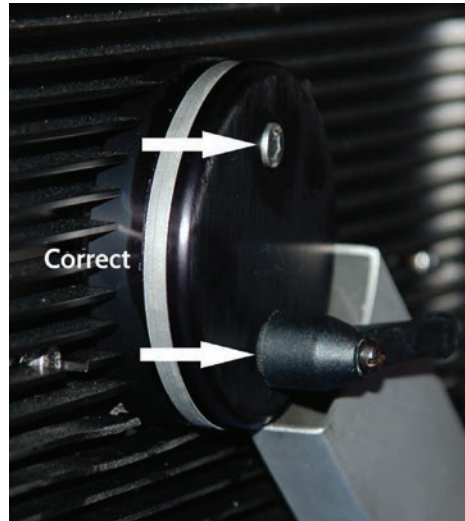

If the yoke locking plates are attached backwards – larger hole above, smaller hole below – the yoke fixing screw as well as the Allen screw cannot be screwed on properly as shown in the picture:

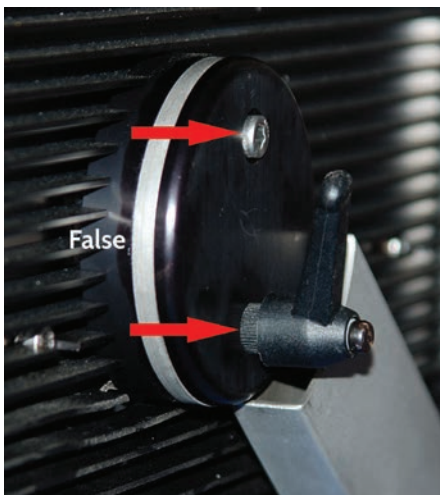

If the yoke is not correctly mounted, a stable attachment of the projector e.g. to a tripod is not guaranteed!

5.1.3 Standing Operation

Place the PHAENON XD in upright position on a stable platform and make sure that the position is sufficiently ventilated.

Do not place the laser unit sideways and do not block the side panels because the air ventilation takes place through the side panels, (see picture):



5.1.4 Hanging Operation

The PHAENON XD is equipped with an extra stable stainless steel yoke for hanging operation (truss or tripod). For mounting you will need minimum one C-clamp (not included).

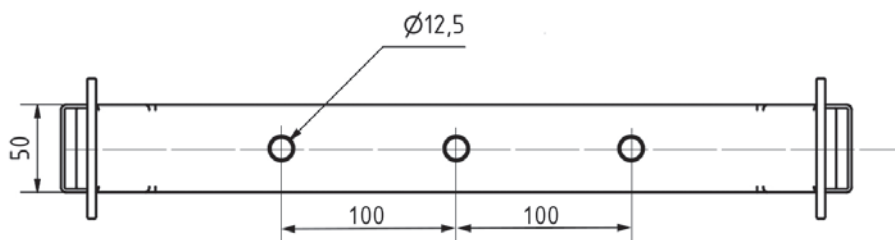

Make sure that the position is sufficiently ventilated.



Make sure that the projector is adequately secured by an additional steel cable during hanging operation. The manufacturer does not assume responsibility for damage to persons or to property due to faulty attachment!

5.1.5 Hints for Application of the included Beam Blocker

A beam blocking set containing spacers, knurled screws and beam blocking shades is included with the shipment for safety reasons. This convenient set can be used to blank the laser output in order to protect the audience in a certain area.

The components of the set have to be mounted beneath the laser emission window as follows:

1. Remove the knurled screws from the spacers and mount the spacers to the provided holes above or below the laser output window.



2. Mount both L-shaped shades together with the beam blocking shade using the knurled screws to the spacers.

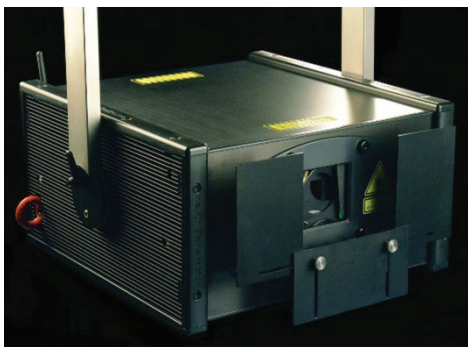

3. Before you tighten the screws put the beam blocking shade to the desired position and fix it by the knurled screws:



5.2 Commissioning

5.2.1 Power On

The device is not equipped with a power switch. The power supply should only be performed by connecting respectively disconnecting the unit to or from the mains.

1. Connect the included power cord to the mains input of your device: Pull the slider, insert the connector and turn it clockwise until the connector is locked.



2. Connect the device to a power outlet. If mains power is available the fans will start and the „Status“ LED will light up.
3. To turn off the projector turn the connector counterclockwise and disconnect it from the mains input „Power“. The powerCON TRUE1 connector can be connected or disconnected under load!

5.2.2 Laser On



Never look into the emission window while turning the laser on! Make sure that no persons or highly combustible materials are located in the path of the laser beam.

1. Open the laser output window by sliding the safety screen to the side.



2. Make sure that the Interlock loop is closed.
3. Insert the key and switch the laser on by turning the key to the right.
 Vertical key position means „Laser off“, horizontal key position means „Laser on“.



The device will now be initialized. The laser is now able to emit laser light as signaled by the emission LED on the rear panel as well as the emission LED on the front panel. The laser beam emission is activated 7 seconds after turning the key switch to „Laser on“



The laser beam emission is activated 7 s after turning the key switch to „Laser on“

4. The laser can be switched-off without delay by turning the key switch counter-clockwise to the vertical position.

5.2.3 Blink sequences of the Status LED

The status LED on the rear indicates the momentary operating status of the device.

Green blinking sequences signalizes normal operation, **red** ones an error state:

Blinking Sequence	Meaning
Alternate red/green blinking	The laser is in „Adjusting“ mode, temperatures have not reached their target values yet.
Green constantly on	The laser is in „Run“ or „Test10%“ mode. ILDA signal is present for laser emission, laser emission can start..
Green blinking 1 times	The device is in the „Shutdown“ mode.
Green blinking 2 times	Interlock loop is open.
Green blinking 3 times	Key switch is not closed.
Green fast blinking emission LED is off	Laser is in the „Standby“ mode, interlock and key switch are closed.
Green fast blinking emission LED is constantly on	<p>Laser is in the automatic „Standby“ or „Shutdown“ mode.</p> <p>This occurs if the laser is in the „Run“ mode but no ILDA signal has been present for more than some seconds (adjustable). The laser switches back to „Run“ immediately when the ILDA signal comes back again.</p> <p>A lot of heat dissipation can be saved in this mode. Your projector stays cooler especially in higher ambient temperatures. The power of the fans will be reduced -> less noise.</p>
Red Blinking	<p>Warning!</p> <p>The temperature sensor for the heat sink or the RTC (Real Time Clock) is failing. However, the laser can still be operated.</p>
Red constantly on	<p>Error!</p> <p>1. If „Run“ or „Test“ modes are no longer possible a system error has occurred.</p> <p>2. If „Run“ and „Test“ modes are still possible, it means that one or more laser disable drivers have signalized an error.</p>

6 Control

The projector can easily be operated using the LA.toolbox software for installation on a PC running Windows or an Apple Mac computer. Please note the minimum requirements for installing the LA.toolbox software. The LA.toolbox as part of the LA.tools Software Suite can be downloaded on <https://laseranimation.com/en/downloads/>

6.1 Operation via LA.toolbox Software

This intuitive software allows for monitoring for important functions of the laser unit and adjustment of operating parameters.

The LA.toolbox communicates via the LAN with the laser projector. This software is a part of the LA.tools Software Suite. The minimum requirements and more details on LA.tools / LA.toolbox can be found on <https://laseranimation.com/en/product/la-tools/>

The PC and Mac versions as well as the detailed LA.toolbox manual are stored on the included USB memory stick or can be downloaded from the LaserAnimation's website (see links above).

Please install the LA.tools Software Suite including LA.toolbox on your PC or Mac to operate the laser projector by the LA.toolbox.



For additional information, please consult the LA.toolbox manual.



LaserAnimation Sollinger GmbH | Crellestr. 19/20 | D-10827 Berlin
 Phone +49 (30) 780 963 00 | Fax +49 (30) 780 963 25
 Email info@laseranimation.com | www.laseranimation.com
 Copyright © LaserAnimation Sollinger GmbH. All rights reserved



7 Pin Assignments

7.1 ILDA in, ILDA thru

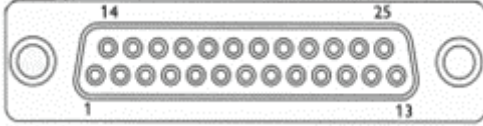

ILDA thru (25pin D-sub female)

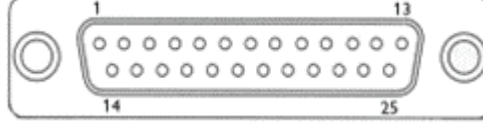

ILDA in (25 pin D-sub male)

Signal	Pin	Level	Remarks
X	1	±10V	Beam position: +10V : right 0V : center - 10V : left
	14		
Y	2	±10V	Beam position: +10V : top 0V : center - 10V : bottom
	15		
Intensity	3	0V or 5V digital signal	0V: Beam off / blanked 5V: Beam on Left open: Beam on Interpretation of this signal can be switched off.
	16		
Interlock	4		Interlock loop
	17		
Red	5	0V to +5V	0V : 0% red 5V : 100% red
	18		
Green	6	0V to +5V	0V : 0% green 5V : 100% green
	19		
Blue	7	0V to +5V	0V : 0% blue 5V : 100% blue
	20		
Indigo	8	0V to +5V	0V : 0% indigo 5V : 100% indigo
	21		
Yellow	9	0V to +5V	0V : 0% yellow 5V : 100% yellow
	22		
Cyan	10	0V to +5V	0V : 0% cyan 5V : 100% cyan
	23		
No signal	11	n.s.	
No signal	12	n.s.	
Shutter	13	0V to +5V	Signal not interpreted
	25		
No signal	24	n.s.	

Notes: n.s. means not supported | All signal lines are true differential.

7.2 Remote Connector

7pin XLR-Jack female



Pin No.	Signal	Meaning
1	Interlock	Interlock loop: INTERLOCK ON: if both Interlock lines are connected to each other
2	Interlock	
3	n.s.	n.s.
4	Remote Key	KEY ON (external key switch): if connected to VCC (pin 6)
5	n.s.	n.s.
6	VCC	+24V max. 250mA
7	GND	Ground

7.2.1 Interlock Plug (included)

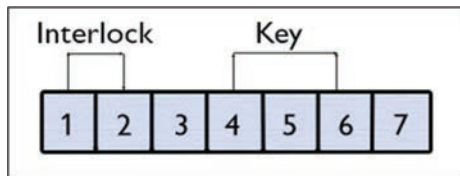

Note:

Please use only the silver colored Interlock connectors for the PHAENON XD projectors. The black Interlock connectors delivered with the old PHAENON/BLITZ series devices do not have the necessary bridge of pins 4 and 6. On the other hand, the silver Interlock connectors will work with the older devices. However, the internal interface of these devices will be disabled by the bridging of pins 4 and 6.



7.3 DMX

Projectors with integrated grating module:



DMX in (male) DMX thru (female)

Pin No.	DMX in	DMX thru
1	DMX Shield	DMX Shield
2	DMX In-	DMX THRU-
3	DMX In+	DMX THRU+
4	n.c.	n.c.
5	n.c.	n.c.

Please note that „DMX in“ is not terminated with 120 Ohm. This needs to be done externally (most easily using a terminating connector on „DMX thru“).

Projectors with integrated Lasergraph DSP compact (with or without grating module):



DMX in (male) DMX thru (female) DMX out (female)

Pin No.	DMX in	DMX thru	DMX out
1	DMX Shield	DMX Shield	DMX Shield
2	DMX In-	DMX THRU-	DMX Out-
3	DMX In+	DMX THRU+	DMX Out+
4	n.c.	n.c.	n.c.
5	n.c.	n.c.	n.c.

8 Grating Module

8.1 Components

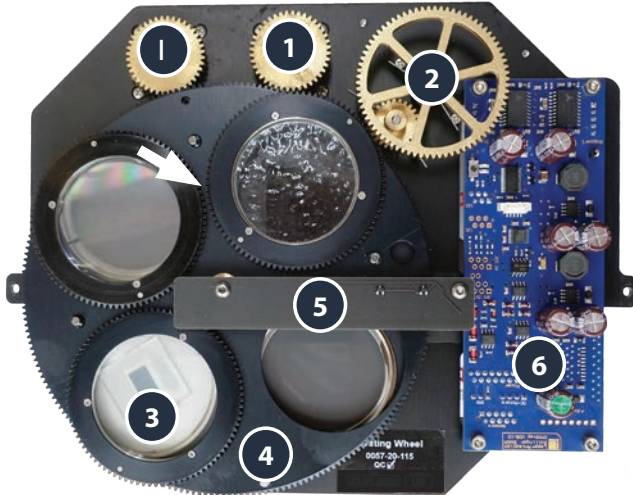

1. Stepper motor (2 pcs.)
2. Gear motor (2 pcs.)
3. Wheel (2 pcs.)
4. Grating (6 pcs.)
5. Sensor board
6. Electronic component for motor control and signal processing



The wheels are equipped with the following glass gratings (by default):



- Wheel 1: Grid WT, Machado (ultra fine line), SCNT (frost effect)
- Wheel 2: Grid XT, Line, Lumia Ultra 100CC (water effect)

Additional we offer more glass gratings which can be inserted instead of a default grating:

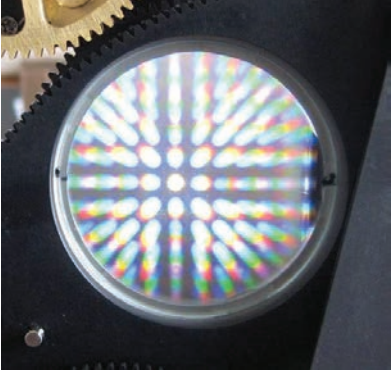
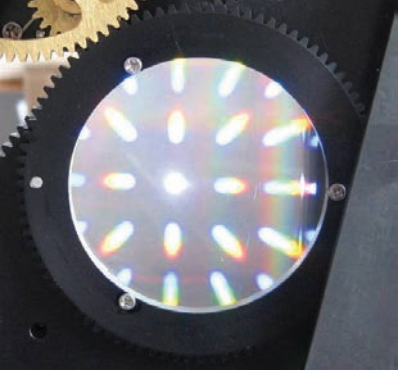
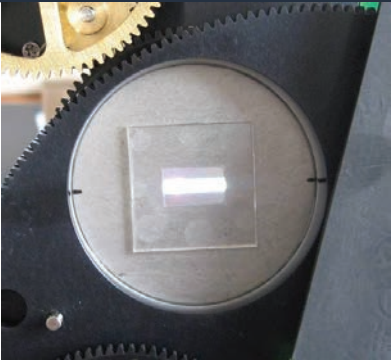
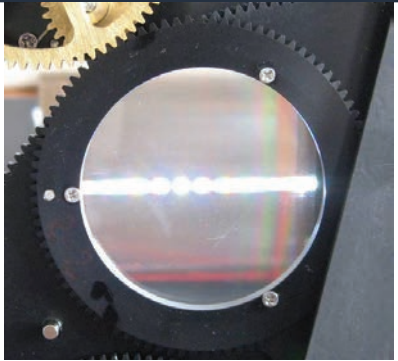
- Lumia wide (wide haze)
- Lumia narrow (narrow haze)
- Stargate

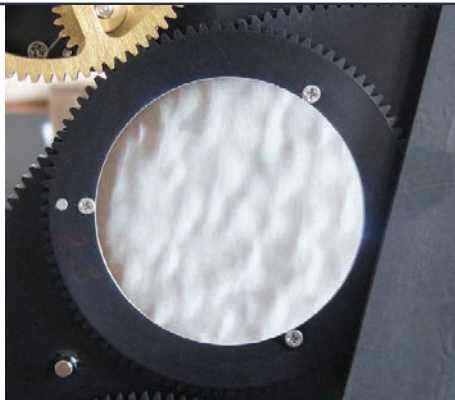
8.2 Default Assembly

Grating Wheel 1 1-1 GWT-2-50C	Grating Wheel 2 2-1 GXT-1-50C
	
1-2 Machado 	2-2 LWT-2-50C 
1-3 SCNT 	2-3 Lumia Ultra 100CC 

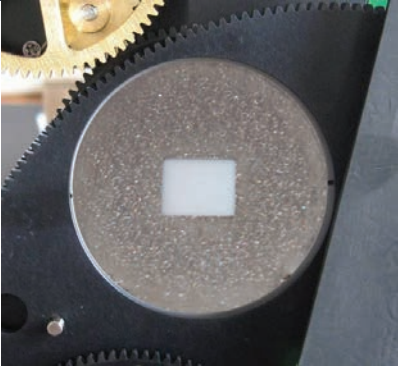
Grating Wheel 1	Grating Wheel 2
<p data-bbox="391 383 564 409">Lumia narrow</p> 	<p data-bbox="1043 383 1185 409">Lumia wide</p> 
<p data-bbox="427 831 528 857">Stargate</p>	
	

8.3 Channel Assignment

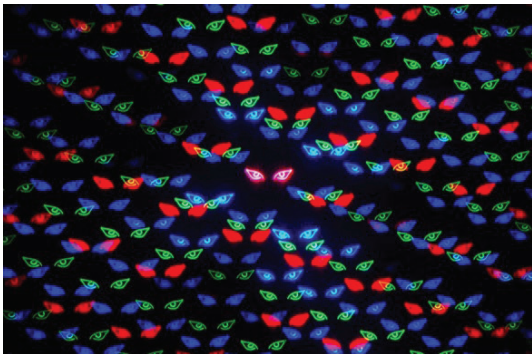
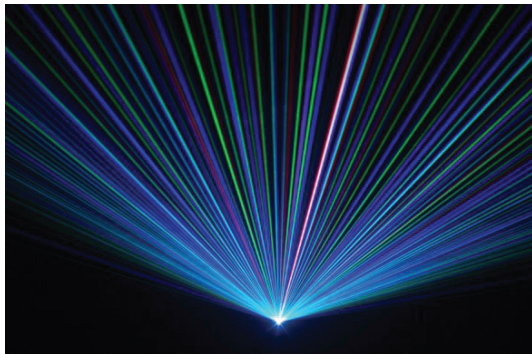
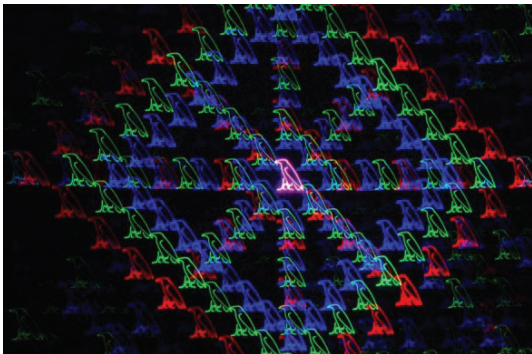
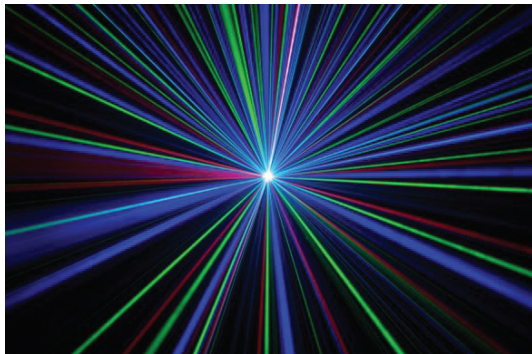

DMX Channel 1: Grating Wheel 1							
Value (Dec)	Value (Hex)	Value (%)	Value (DSP)	Function		Grating Name	Output
0...63	0...3F	0...24.7	0... 0.246	No Grating			
64	40	25.1	0.25	Grating 1 rotating	speed defined by channel 2	Grid GWT-2	see pic. 1
65	41	25.5	0.254	Grating 1 position mode	- 90°		
80	50	31.4	0.313		- 45°		
96	60	37.65	0.375		0° (horizontal)		
112	70	43.9	0.438		+ 45°		
127	7F	49.8	0.496		+ 90°		
128	80	50.2	0.5	Grating 2 rotating	speed defined by channel 2	Machado	see pic. 2
129	81	50.6	0.504	Grating 2 position mode	- 90°		
144	90	56.5	0.563		- 45°		
160	A0	62.7	0.625		0° (horizontal)		
176	B0	69	0.688		+ 45°		
191	BF	74.9	0.746		+ 90°		
192	C0	75.3	0.75	Grating 3 rotating	speed defined by channel 2	Stargate	see pic. 3
193	C1	75.7	0.754	Grating 3 position mode	- 90°		
208	D0	81.6	0.813		- 45°		
224	E0	87.8	0.875		0° (horizontal)		
240	F0	94.1	0.938		+ 45°		
255	FF	100	1.000		+ 90°		

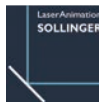
Grating Wheel I	
Grating 1 Grid GWT-2	Grating 2 Machado
	
Grating 3 Stargate	
Graphics Effect	Beam Effect
	



DMX Channel 2: Grating Wheel 1 - Rotating Speed of the Grating							
Value (Dec)	Value (Hex)	Value (%)	Value (DSP)	Function			
0	0	0	0.00	full speed reverse			
128	80	50,2	0.50	stop (position undefined)			
255	FF	100	1.00	full speed normal			
DMX Channel 3: Grating Wheel 2							
Value (Dec)	Value (Hex)	Value (%)	Value (DSP)	Function	Grating Name	Output	
0...63	0...3F	0...24.7	0... 0.246	No Grating			
64	40	25.1	0.25	Grating 1 rotating	Grid GWT-1	see pic. 4	
65	41	25.5	0.254	Grating 1 position mode			- 90°
80	50	31.4	0.313				- 45°
96	60	37.65	0.375				0° (horizontal)
112	70	43.9	0.438				+ 45°
127	7F	49.8	0.496				+ 90°
128	80	50.2	0.5	Grating 2 rotating	Line LWT-2	see pic. 5	
129	81	50.6	0.504	Grating 2 position mode			- 90°
144	90	56.5	0.563				- 45°
160	A0	62.7	0.625				0° (horizontal)
176	B0	69	0.688				+ 45°
191	BF	74,9	0.746				+ 90°
192	C0	75.3	0.75	Grating 3 rotating	Lumia	see pic. 6	
193	C1	75.7	0.754	Grating 3 position mode			- 90°
208	D0	81.6	0.813				- 45°
224	E0	87.8	0.875				0° (horizontal)
240	F0	94.1	0.938				+ 45°
255	FF	100	1.000				+ 90°

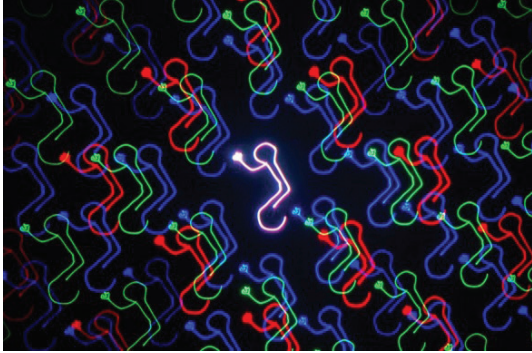

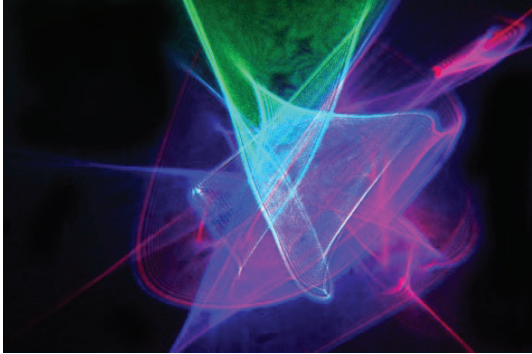
Grating Wheel 2	
Picture 4: Wheel 2 Grating Grid GXT-I	Picture 5: Wheel 2 Grating 2 Line
	
Picture 6: Wheel 2 Grating 3 Lumia wide	
	

DMX Channel 4 Grating Wheel 2 - Rotating Speed of the Grating

Value (Dec)	Value (Hex)	Value (%)	Value (DSP)	Function
0	0	0	0.00	full speed reverse
128	80	50,2	0.50	stop (position undefined)
255	FF	100	1.00	full speed normal

DMX Channel 5: Focus Control - devices with focus control only

Value (Dec)	Value (Hex)	Value (%)	Value (DSP)	Function
0	0	0	0.00	Minimum divergence (default)
255	FF	100	1.00	full speed normal

DMX Channel 6: Reset

Value (Dec)	Value (Hex)	Value (%)	Value (DSP)	Function
0	0	0	0.00	Normal operation (default)
1...31	1...1F	6.25	0.063	Reset both wheels
32...63	20...3F	18.75	0.188	Reset focus
64...95	40...5F	31.25	0.313	Reset all

Note: Select always 0 before you select a trigger, then trigger minimum 1 sec.

8.4 Controlling the Grating Module

8.4.1 DMX signal routing

Adjust the DMX address in the Main Tab of LA.toolbox.

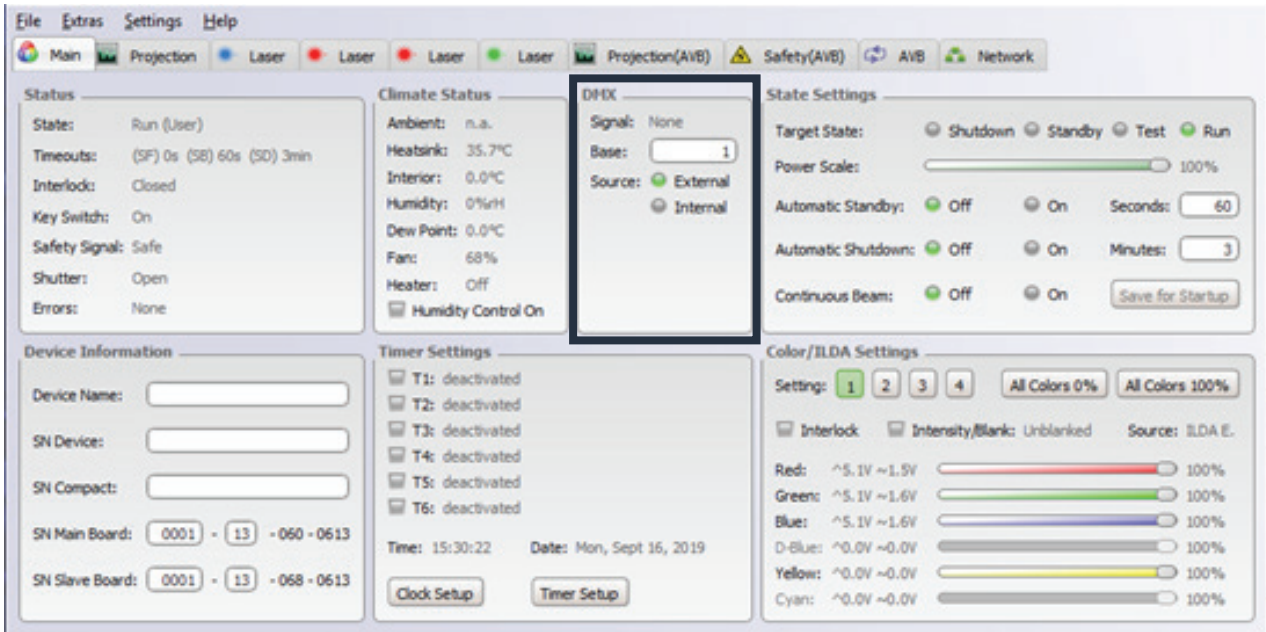

The device internal DMX address of the Grating Wheel is set (LA.toolbox:Tab Grating Wheel) to 1 and should not be changed.

8.4.1 Controlling the Grating Module Using an internal Lasergraph DSP compact

Please check if „DMX“ is enabled in the block „Grating Wheel“ of the LA.toolbox software:

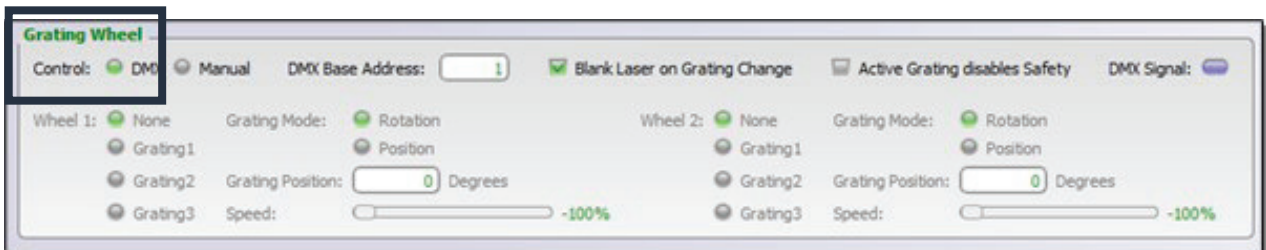

Start the program „LGRemote“ on your PC or Mac in order to connect with the internal Lasergraph DSP compact:

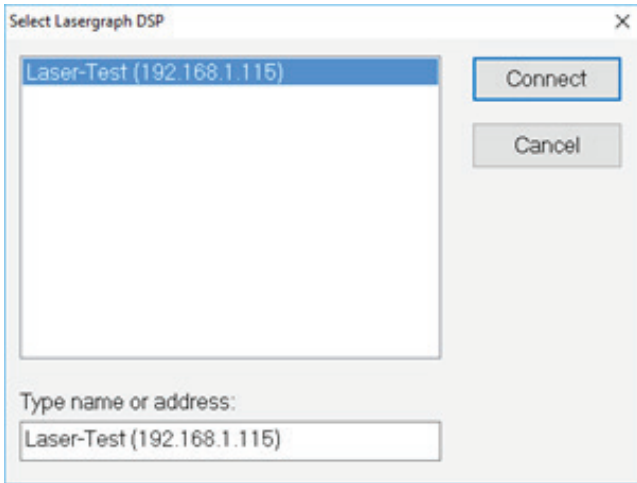

Select [File] from the menu bar of the Lasergraph DSP compact user interface and load the Bankconfig file „GratingWheel.BCFG“ from the directory „C:\System“:

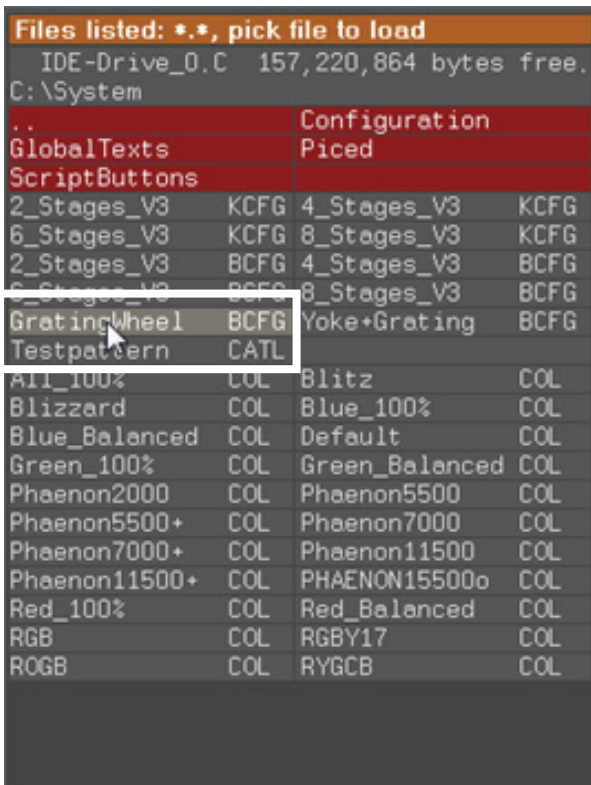

Then return to the Lasergraph DSP compact start screen and select „Keyboard configuration“ or [Keyconf] from the menu bar

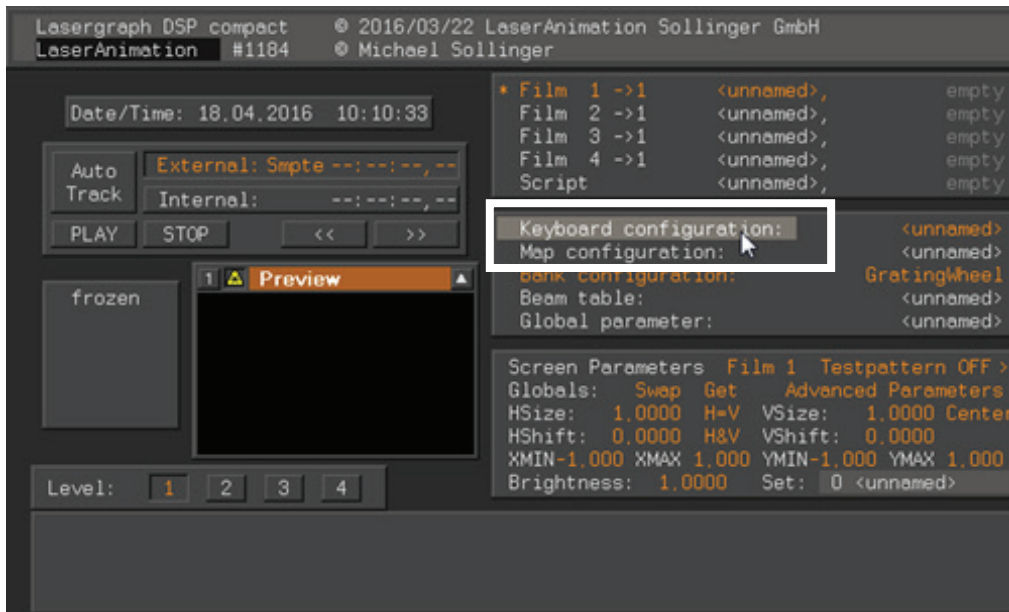

to open the following window:

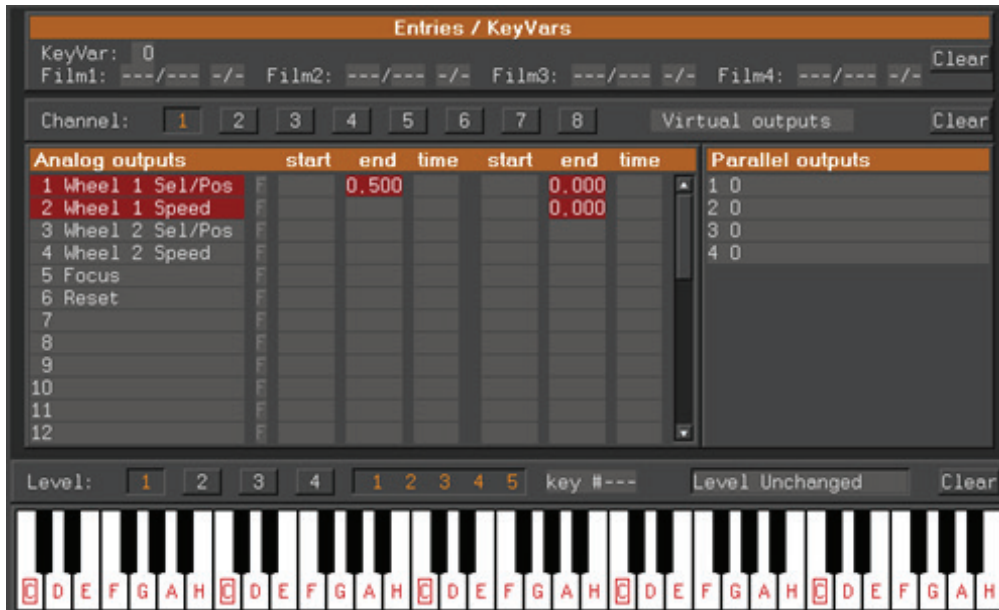

Here you can enter the „DSPValues“ specified in the previous tables (item 7) in the columns named „end“.

9 Maintenance Hints



Turn the laser off and disconnect the device from the mains before doing any maintenance!

Do not touch the laser emission window and always close it with the protector after operation.



The laser emission window can be polluted during the operation (fog machines, open air operation etc.). A polluted window can reduce the laser output power and influence the beam quality. We recommend the laser output window to be cleaned from time to time. Please use methanol (against finger prints) and/or acetone and lens paper for cleaning.

Be carefully during cleaning and do not touch the cleaning surface of the lens paper with your fingers.

Methanol and Acetone are hazardous materials: Please observe the related precautions!

The housing of the device may be cleaned with a soft fluff-less cloth and a mild detergent.

Please check the air inlets and outlets on both sides of the housing from time to time. Remove any dust between the ribs using a brush, a vacuum cleaner or oil-free compressed air.

10 Malfunction

Check the mains connection!

In case of malfunction please check the mains connection and mains cable first. If necessary change the mains cable.

In case of other malfunctions please send the device to your dealer for inspection and repair in its original packing.

II Operation with UPS

The mains supply at events may be „contaminated“ (e.g. voltage peaks) due to a large number of connected devices (e.g. dimmers etc.).

In adverse conditions this could cause problems in the operation of the laser projector.



To ensure safe operation of the laser anytime it is highly recommended to run the laser with the aid of a UPS (Uninterrupted Power Supply).

It is recommended to protect your valuable laser equipment by a cheap, readily available device!

The UPS can be obtained from any supplier for electric appliances or computers. It is set up between the mains supply and the mains connector of the laser projector and ensures a clean AC voltage.

The best choice is a „double-conversion“ or „online“ UPS – double conversion means Voltage Frequency Independent (VFI). It protects your high-value equipment against power failures, voltage drops or spikes and frequency fluctuations.

We recommend the online UPS type

APC Smart-UPS SRT 2200 VA, 230 V SRT2200XLI“ by APC Schneider Electric Inc.

It is essential to check if protective earth (PE) is available at the connection side of the UPS, because the best UPS doesn't help without protective earth (PE).

Please set the following parameters as specified:

- Bypass: Disabled
- Frequency: Fixed 50Hz
- Voltage: Fixed 230VAC



12 Technical Drawings - PHAENON XD (Regular Housing)

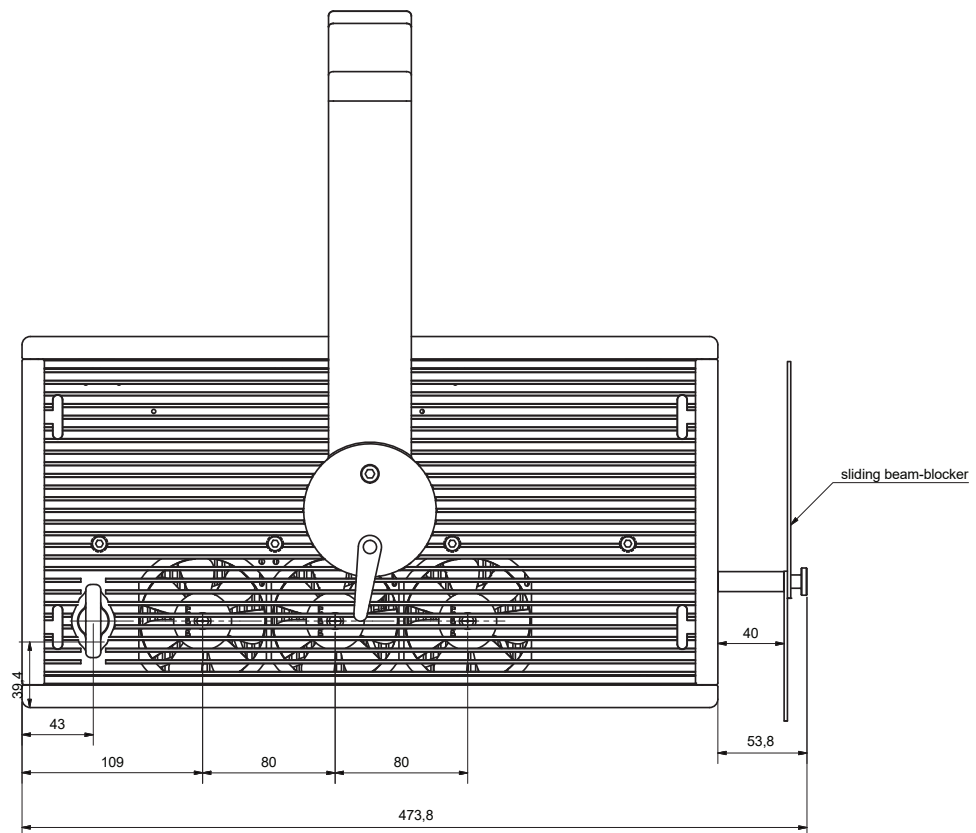
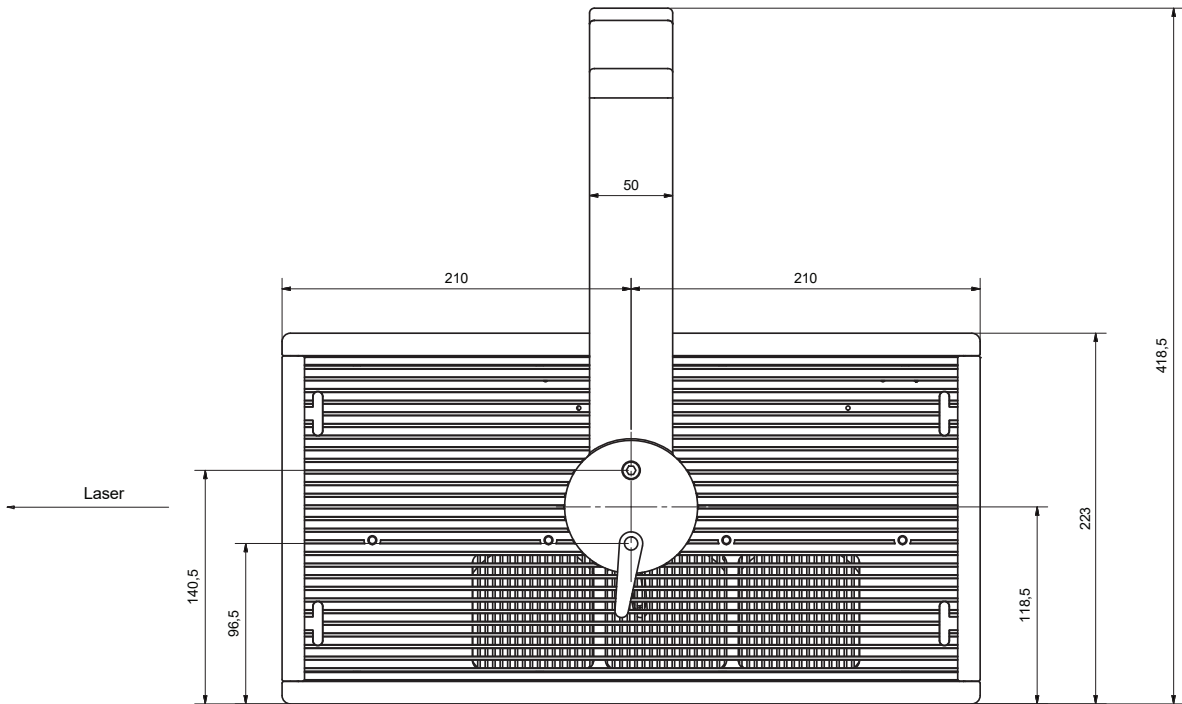

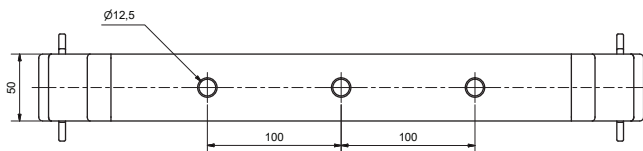
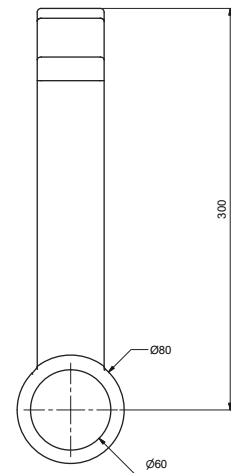
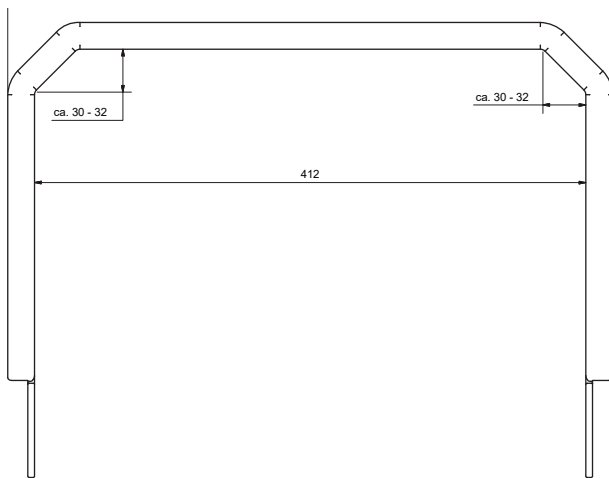
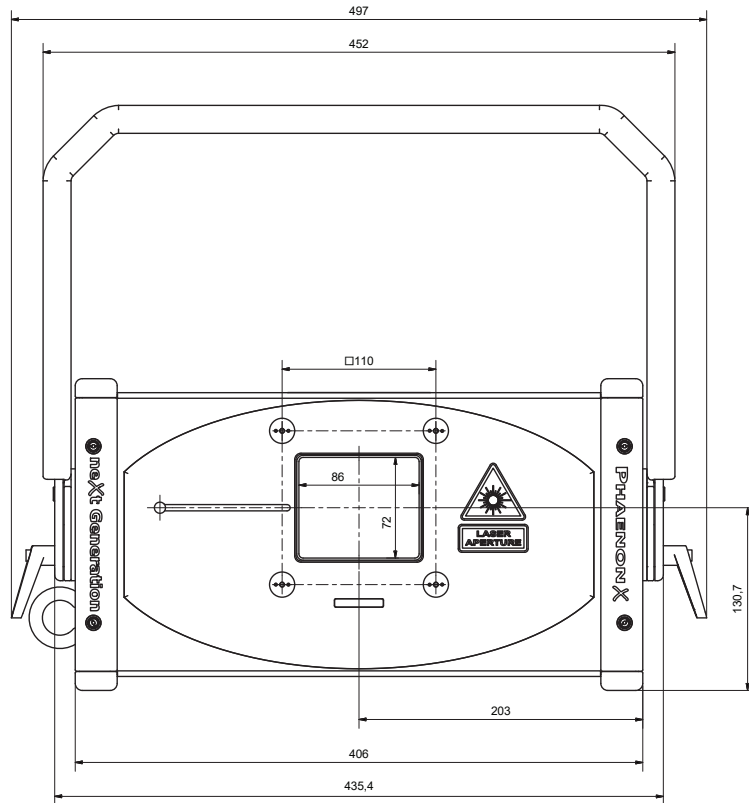

PHAENON XD
 Dimensions in mm
 © LaserAnimation Sollinger GmbH



LaserAnimation Sollinger GmbH | Crellestr. 19/20 | D-10827 Berlin
 Phone +49 (30) 780 963 00 | Fax +49 (30) 780 963 25
 Email info@laseranimation.com | www.laseranimation.com
 Copyright © LaserAnimation Sollinger GmbH. All rights reserved



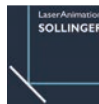

13 Technical Specifications

Device dimensions (L x W x H)	420 x 406 x 223 mm (w/o bracket)					
Laser Source	Laser sources (depending on model) Diode (red / blue) OPSL (blue / yellow / orange / cyan)					
Type	CW analog modulated, laser class 4					
Typical wavelengths	638 nm red diode	532 nm green OPSL	445 nm blue diode	488 nm cyan OPSL	577 nm yellow OPSL	590 nm orange OPSL
Scanner	CT 6210 with Turboscan XD scan driver					
Scan system speed	60 kpps ILDA 8°					
Scan angle	max. 80°, 50° typical					
Reaction time (2° opt. step)	< 0,2 ms, aperture: 4 mm					
Scan fail safety	500°/s minimum scanner speed					
Observation time	1 ms					
Aperture	4 mm					
Operation mode	AVB / TSN interface, AIFF player function, stand-alone player, ILDA, DMX / Art Net, Control software "LA.toolbox" included					
Power supply	85 VAC – 264 VAC, 50 - 60 Hz, universal					
Operating temperature	- 5°C - +50°C					
IP rated	IP54					
Connectors						
AC Mains Connector	powerCON TRUE1					
Projector Signal, analog	ILDA in, ILDA thru, D-sub 25 differential inputs					
Remote	7pin XLR (external key switch, interlock)					
DMX in /thru	5pin XLR					
LAN	RJ-45 Jack					
Optional Built-In						
Grating module (Two effect wheels each equipped with three glass gratings)	Gratings Wheel 1:			Gratings Wheel 2:		
	I-1 GWT-2			2-1 Lumia Claude's Special		
	I-2 Machado			2-2 LWT-2		
	I-3 LWT-2			2-3 Lumia narrow 528		
	Gratings Wheel 1:			Gratings Wheel 2:		
	I-1 GWT-2			2-1 Lumia Claude's Special		
	I-2 Stargate			2-2 LWT-2		
	I-3 LWT-2			2-3 Cokin 4 Star		



Device-dependent laser specifications				
PHAENON XD 20000				
Total power (after optics)	19,000 mW			
Power per color	6400 mW (638 nm)	8000 mW (532 nm)	8000 mW (445 nm)	
Beam divergence*	< 0.5 mrad*			
Beam diameter	4.5 mm			
Power consumption	650 W			
Weight (net)	28 kg			
PHAENON XD 22000 O				
Total power (after optics)	21,000 mW			
Power per color	6400 mW (638 nm)	8000 mW (532 nm)	8000 mW (445 nm)	3000 mW (590 nm)
Beam divergence*	< 0.5 mrad*			
Beam diameter	4.5 mm			
Power consumption	950 W			
Weight (net)	31 kg			
PHAENON XD 25000 Y				
Total power (after optics)	23,000 mW			
Power per color	6400 mW (638 nm)	8000 mW (532 nm)	8000 mW (445 nm)	5000 mW (577 nm)
Beam divergence*	< 0.5 mrad*			
Beam diameter	4.5 mm			
Power consumption	950 W			
Weight (net)	31 kg			
PHAENON XD 24000				
Total power (after optics)	21,000 mW			
Power per color	9600 mW (638 nm)	8000 mW (532 nm)	8000 mW (445 nm)	
Beam divergence*	< 0.6 mrad*			
Beam diameter	4.5 mm			
Power consumption	650 W			
Weight (net)	30 kg			



LaserAnimation Sollinger GmbH | Crellestr. 19/20 | D-10827 Berlin
 Phone +49 (30) 780 963 00 | Fax +49 (30) 780 963 25
 Email info@laseranimation.com | www.laseranimation.com
 Copyright © LaserAnimation Sollinger GmbH. All rights reserved





PHAENON XD 30000 Y					
Total power (after optics)	26,000 mW				
Power per color	9600 mW (638 nm)	8000 mW (532 nm)	8000 mW (445 nm)	6000 mW (577 nm)	
Beam divergence*	< 0.6 mrad*				
Beam diameter	4.5 mm				
Power consumption	950 W				
Weight (net)	32 kg				
PHAENON XD 35000 YC					
Total power (after optics)	31,000 mW				
Power per color	9600 mW (638 nm)	8000 mW (532 nm)	8000 mW (445 nm)	6000 mW (577 nm)	6000 mW (488 nm)
Beam divergence*	< 0.6 mrad*				
Beam diameter	4.5 mm				
Power consumption	1200 W				
Weight (net)	43 kg				
Device dimensions (L x W x H)	620 x 406 x 223 mm (w/o bracket)				

*FWHM average depending on model



LaserAnimation Sollinger GmbH | Crellestr. 19/20 | D-10827 Berlin
 Phone +49 (30) 780 963 00 | Fax +49 (30) 780 963 25
 Email info@laseranimation.com | www.laseranimation.com
 Copyright © LaserAnimation Sollinger GmbH. All rights reserved



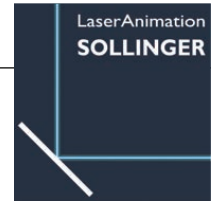
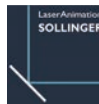
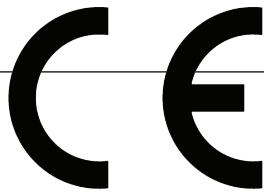

EU Declaration of Conformity

Manufacturer:

LaserAnimation Sollinger GmbH

Product Name:

PHAENON XD 20000
PHAENON XD 22000 O
PHAENON XD 25000 Y

PHAENON XD 24000
PHAENON XD 30000 Y
PHAENON XD 35000 YC

Products covered by this declaration: Laser display systems

We here declare that the product described above is in conformity with the following directives:

- 2014/35/EU Low Voltage Directive
- 2014/30/EU Electromagnetic Compatibility Directive
- 2014/53/EU Directive for harmonisation of the laws of the Member States relating to the making available on the market of radio equipment

The following harmonized standards have been applied:

- DIN EN 61000-6-1 VDE 0839-6-1:2007-10
Electromagnetic compatibility (EMC)
Part 6-1: Generic standards - Immunity for residential, commercial and light-industrial environments
- DIN EN 61000-6-2 VDE 0839-6-2:2006-03
Electromagnetic compatibility (EMC)
Part 6-2: Generic standards - Immunity for industrial environments
- DIN EN 61000-6-3 VDE 0839-6-3:2011-09
Electromagnetic compatibility (EMC)
Part 6-3: Generic standards – Emission standard for residential, commercial and light-industrial environments
- DIN EN 61000-6-4 VDE 0839-6-4:2011-09
Electromagnetic compatibility (EMC)
Part 6-4: Generic standards – Emission standard industrial environments
- DIN EN 60825-1 VDE 0837-1:2015-07
Safety of laser products
Part 1: Equipment classification and requirements
- DIN EN 55032:2016-02 VDE 0878-32:2016-02
Electromagnetic compatibility of multimedia equipment - Emission Requirements

The included technical documents (files) demonstrate that the product has been produced according to the requirements of the abovementioned directives.

The EU declaration of conformity is available for inspection by the market surveillance authorities at any time.

Berlin, 11.03.2024

Martin Werner



LaserAnimation Sollinger GmbH | Crellestr. 19/20 | D-10827 Berlin
Phone +49 (30) 780 963 00 | Fax +49 (30) 780 963 25
Email info@laseranimation.com | www.laseranimation.com
Copyright © LaserAnimation Sollinger GmbH. All rights reserved



Final statement

All our products and their packaging are individually checked and leave our facilities in a flawless and proper condition. If you notice any damage or defects when receiving the product, please contact your dealer immediately. Damages caused by improper handling are not subject to the manufacturer's or dealer's responsibility and no liability or warranty is assumed for it. The operator of the device must follow the local safety regulations and the warnings in the manual. If changes are made to this manual, we cannot inform you. Please contact your dealer for service and any other questions. Only use original spare parts.

Subject to change without notice. No warranty can be given for the correctness of the information.

LaserAnimation Sollinger GmbH
Crellestr. 19/20
10827 Berlin
Germany

Place of Business: Berlin, Germany | Registry Court: Amtsgericht Charlottenburg, HRB 45888 | Managing Director: Martin Werner | VAT-ID: DE154202159

E-Mail: info@laseranimation.com
Internet: www.laseranimation.com



LaserAnimation Sollinger GmbH | Crellestr. 19/20 | D-10827 Berlin
Phone +49 (30) 780 963 00 | Fax +49 (30) 780 963 25
Email info@laseranimation.com | www.laseranimation.com
Copyright © LaserAnimation Sollinger GmbH. All rights reserved

